



# BLUE controller

your  $\mu$ controller & wireless shop



## $\mu$ Controller

*AVR AVR32 ARM and other IC's*

## Radio Modules

*Bluetooth and wireless*

## LCD & TFT

*Optoelectronics, LC and TFT Displays*

## PCB's

*Universal development PCB's*

This datasheet have been downloaded from:

**BLUEcontroller.com**

## UNIVERSAL ISM BAND FSK TRANSCEIVER MODULE

### WITH 500mW OUTPUT POWER

### RFM12BP

(the purpose of this spec covers mainly for the physical characteristic of the module, for register configure and its related command info please refer to [RF12B datasheet](#))

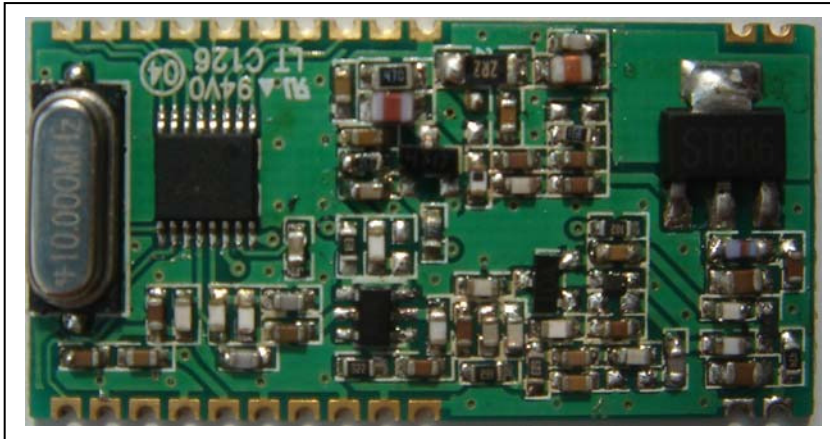

## General Introduction

RFM12BP is a low costing ISM band transceiver module implemented with 500mW output power. It works signal ranges from 433/868/915MHZ bands, The SPI interface is used to communicate with microcontroller for parameter setting.

## Features:

- High output power with 500mW
- High input sensitivity with -116dBm
- Low costing, high performance and price ratio
- PLL and zero IF technology
- Fast PLL lock time
- High resolution PLL with 2.5 KHz step
- High data rate (up to 115.2 kbps with internal demodulator, with external RC filter highest data rate is 256 kbps)
- 50 OHM antenna input/output
- Programmable TX power
- Programmable TX frequency deviation (from 15 to 240 KHz)
- Programmable receiver bandwidth (from 67 to 400 kHz)
- Analog and digital signal strength indicator (ARSSI/DRSSI)
- Automatic frequency control (AFC)
- Data quality detection (DQD)
- Internal data filtering and clock recovery
- RX synchron pattern recognition
- SPI compatible serial control interface
- Clock and reset signal output for external MCU use
- 16 bit RX Data FIFO
- Two 8 bit TX data registers
- Standard 10 MHz crystal reference
- Wakeup timer
- 2.2V – 3.8V power supply for FSK IC, 12V power supply for power amplifier
- Standby current less than 0.3uA
- Supports very short packets (down to 3 bytes)

## Typical Application:

- Remote control
- Remote sensor
- Wireless data collection
- Home security system
- Toys

## Pin Definition:

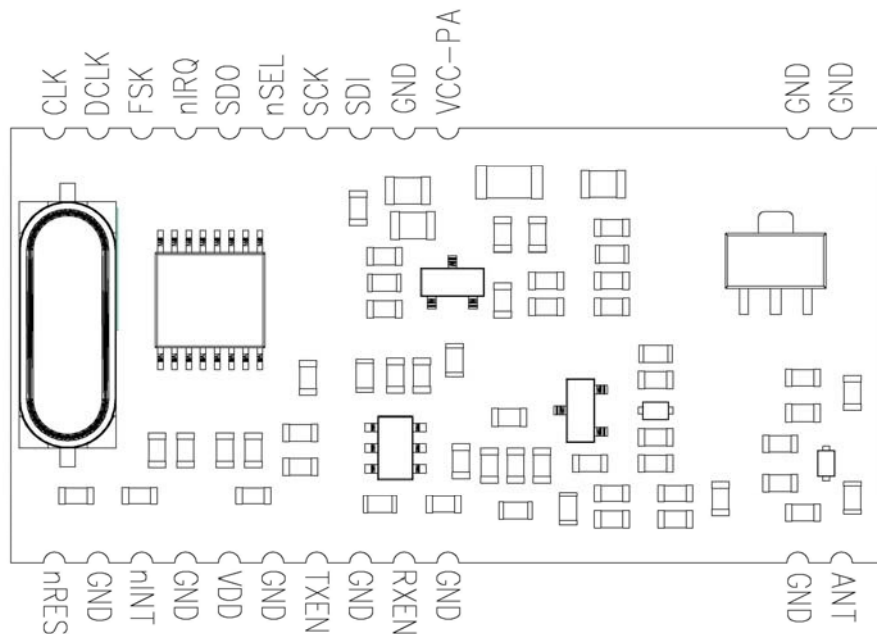

PIN number	definition	Type	Function
1	GND	S	ground
2	GND	S	ground
3	VCC-PA	S	Positive power supply for power amplifier (12V)
4	GND	S	ground
5	SDI	DI	SPI data input
6	SCK	DI	SPI clock input
7	nSEL	DI	Chip select (active low)
8	SDO	DO	Serial data output with bus hold
9	nIRQ	DO	Interrupts request output (active low)
10	FSK/DATA/nFFS	DI/DO/DI	Transmit FSK data input/ Received data output (FIFO not used)/ FIFO select
11	DCLK/CFIL/FIT	DO/AIO/DO	Clock output (no FIFO) / external filter capacitor(analog mode)/ FIFO interrupts(active high)when FIFO level set to 1, FIFO empty interruption can be achieved
12	CLK	DO	Clock output for external microcontroller
13	nRES	DIO	Reset output (active low)
14	GND	S	ground
15	nINT/VDI	DI/ DO	Interrupt input (active low)/Valid data indicator

16	GND	S	ground
17	VDD	S	Positive power supply for FSK IC(2.2V-3.8V)
18	GND	S	ground
19	TXEN	AI	TX enable(active high)
20	GND	S	ground
21	RXEN	AI	RX enable(active high)
22	GND	S	ground
23	GND	S	ground
24	ANT	AIO	RF signal output/input (50 OHM)

## Electrical Parameter:

### Maximum (not at working mode)

symbol	parameter	minimum	maximum	Unit
VDD	Positive power supply for FSK IC	-0.5	4.0	V
VCC-PA	Positive power supply for power amplifier	-0.5	13	V
V <sub>in</sub>	All pin input level except VDD,VCC-PA,GND,ANT	-0.5	VDD+0.5	V
I <sub>in</sub>	Input current except VDD,VCC-PA,GND,ANT	-25	25	mA
ESD	Human body model		1000	V
T <sub>st</sub>	Storage temperature	-55	125	°C
T <sub>ld</sub>	Soldering temperature(10s)		260	°C

### Recommended working range

symbol	parameter	min	max	Unit
VDD	Positive power supply	2.2	3.8	V
T <sub>op</sub>	Working temperature	-40	+85	°C

### DC characteristic

symbol	parameter	Remark	min	typ	max	Unit
I <sub>dd_TX_PMA</sub> x	Supply current (TX mode, P <sub>out</sub> = 500mW)	433MHz band 868/915MHz band		185 200		mA
I <sub>dd_RX</sub>	Supply current (RX mode)	433MHz band 868/915MHz band		20 25		mA
I <sub>x</sub>	Idle current	Crystal oscillator on		0.62	1.2	mA
I <sub>pd</sub>	Sleep mode current	All blocks off		0.3		uA
I <sub>lb</sub>	Low battery detection			0.5		uA
V <sub>lb</sub>	Low battery detect threshold	0.1V per step	2.2		3.8	V
V <sub>lba</sub>	Low battery detection accuracy		0		5	%
V <sub>il</sub>	Low level input				0.3*V <sub>dd</sub>	V
V <sub>ih</sub>	High level input		0.7*V <sub>dd</sub>			V
I <sub>il</sub>	Leakage current	V <sub>il</sub> =0V	-1		1	uA

$I_{ih}$	Leakage current	$V_{ih}=V_{dd}, V_{dd}=4V$	-1		1	uA
$V_{ol}$	Low level output	$I_{ol}=2mA$			0.4	V
$V_{oh}$	High level output	$I_{oh}=-2mA$	$V_{dd}-0.4$			V

## AC characteristic

symbol	parameter	remark	min	typical	max	Unit
$f_{ref}$	PLL frequency		9	10	11	MHz
$f_{LO}$	frequency (10MHz crystal used)	433 MHz band,2.5KHz step 868 MHz band,5KHz step 915 MHz band,7.5KHz step	430.24 860.48 900.72		439.75 879.51 929.27	MHz
$f_{LO}$	frequency (9MHz crystal used)	433 MHz band,2.5KHz step 868 MHz band,5KHz step 915 MHz band,7.5KHz step	387.22 774.43 810.65		395.76 791.56 836.34	MHz
$f_{LO}$	frequency (11MHz crystal used)	433 MHz band,2.5KHz step 868 MHz band,5KHz step 915 MHz band,7.5KHz step	473.26 946.53 990.79		483.73 967.46 1022.2	MHz
BW	Receiver bandwidth	mode 0 mode 1 mode 2 mode 3 mode 4 mode 5	60 120 180 240 300 360	67 134 200 270 350 400	75 150 225 300 375 450	KHz
$t_{lock}$	PLL lock time	After 10MHz step hopping, frequency error <10 kHz		30		us
$t_{st, P}$	PLL startup time	With a running crystal oscillator		200	300	us
BR	Data rate	With internal digital demodulator	0.6		115.2	kbps
BR <sub>A</sub>	Data rate	With external RC filter			256	kbps
$P_{min}$	sensitivity	BER $10^{-3}$ , BW=134KHz, BR=1.2kbps		-117	-115	dBm
AFC <sub>range</sub>	AFC working range	$df_{FSK}$ : FSK deviation in the received signal		$0.8 \cdot df_{FSK}$		

## AC characteristic(Transmitter)

symbol	parameter	remark	min	typical	max	Unit
$P_{max\_50}$	Max. output power delivered to 50Ohm load	433MHZ band 868/915MHZ band		500 500		mW
BR <sub>TX</sub>	FSK bit rate	Via internal TX data register			172	kbps

BRA <sub>TX</sub>	FSK bit rate	TX data connected to the FSK input			256	kbps
df <sub>fsk</sub>	FSK frequency deviation	Programmable in 15 kHz steps	15		240	KHZ

### AC characteristic(Turn-on/Turnaround timings)

symbol	parameter	remark	min	typical	max	Unit
T <sub>st</sub>	Crystal oscillator startup time	Crystal ESR < 100		1	5	ms
T <sub>tx_XTAL_ON</sub>	Transmitter turn-on time	Synthesizer off, crystal oscillator on with 10 MHz step		250		us
T <sub>rx_XTAL_ON</sub>	Receiver turn-on time	Synthesizer off, crystal oscillator on with 10 MHz step		250		us
T <sub>tx_rx_SYNT_ON</sub>	Transmitter – Receiver turnover time	Synthesizer and crystal oscillator on during TX/RX change with 10 MHz step		150		us
T <sub>rx_tx_SYNT_ON</sub>	Receiver – Transmitter turnover time	Synthesizer and crystal oscillator on during RX/TX change with 10 MHz step		150		us
C <sub>xl</sub>	Crystal load capacitance	Programmable in 0.5 pF steps, tolerance+/- 10%	8.5		16	pf
t <sub>POR</sub>	Internal POR timeout	After V <sub>dd</sub> has reached 90% of final value			100	ms
t <sub>PBt</sub>	Wake-up timer clock period	Calibrated every 30 seconds	0.96		1.05	ms
C <sub>in, D</sub>	Digital input capacitance				2	pf
t <sub>r, f</sub>	Digital output rise/fall time	15pF pure capacitive load			10	ns

### Field testing range

Band	Test condition	Distance
433MHz band	Receiver bandwidth =67KHz, data rate=1.2kbps, transmitter frequency deviation =45KHZ (matches with RFM12) In free open area	>3000M
868MHz band	Receiver bandwidth=67KHz,data rate =1.2kbps,Transmitter frequency deviation =45KHZ (matches with RFM12) in free open area	>3000M
915MHz band	Receiver bandwidth=67KHz,data rate =1.2kbps,Transmitter frequency deviation =45KHZ (matches with RFM12) in free open area	>3000M

## Mechanical Dimension

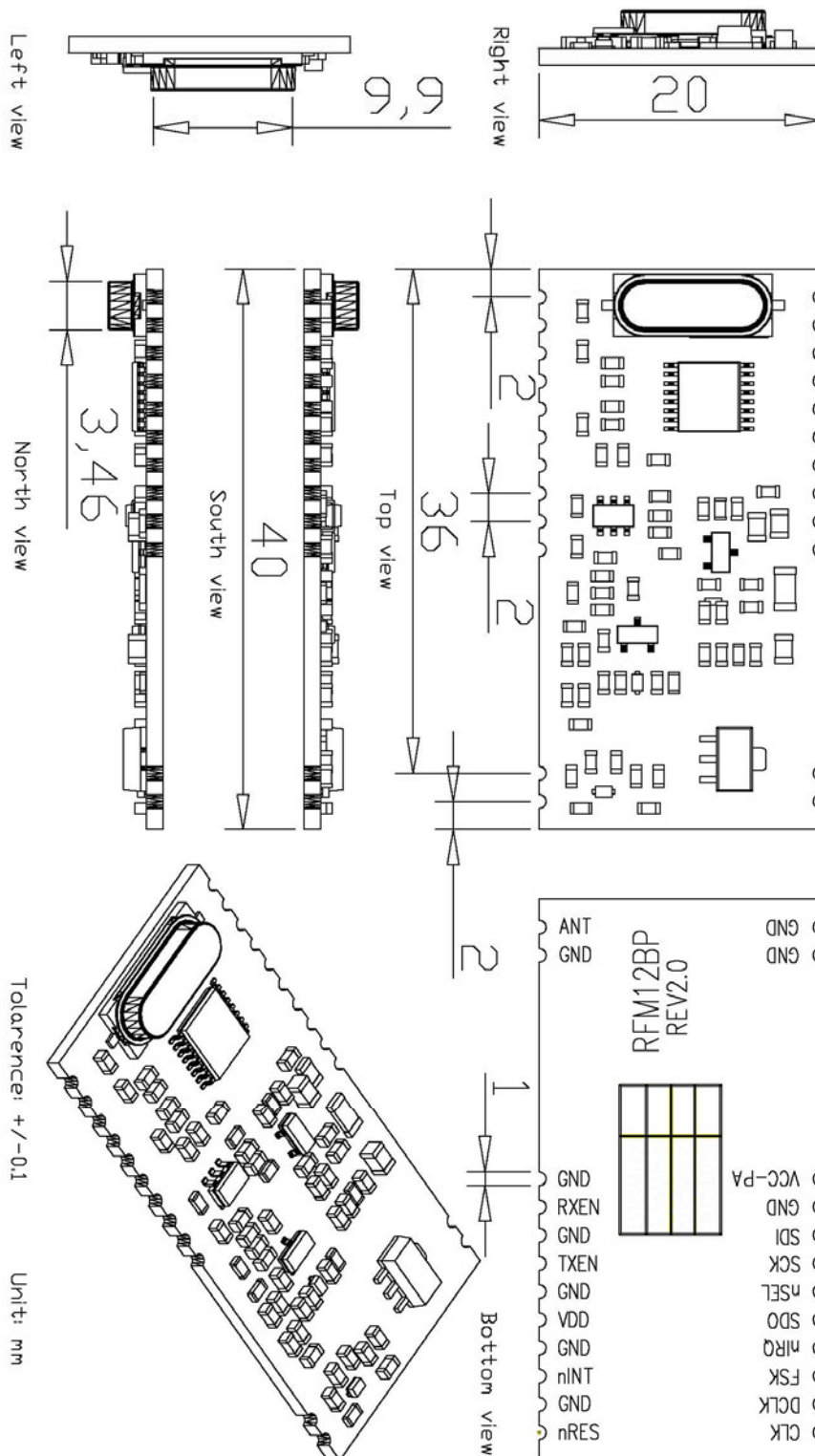

## Module Model Definition

model=module-operation band

RFM12BP – 433

↑  
module type

↑  
operation band

- example: 1, RFM12BP module at 433MHz band, RFM12BP-433.  
2, RFM12BP module at 868MHZ band, RFM12BP-868.

**HOPE MICROELECTRONICS CO.,LTD**  
Rm B.8/F LiJingGe Emperor Regency 6012  
ShenNan Rd., Shenzhen,China  
Tel: 86-755-82973805  
Fax: 86-755-82973550  
Email: [sales@hoperf.com](mailto:sales@hoperf.com)  
[trade@hoperf.com](mailto:trade@hoperf.com)  
Website: <http://www.hoperf.com>  
<http://www.hoperf.cn>  
<http://hoperf.en.alibaba.com>

This document may contain preliminary information and is subject to change by Hope Microelectronics without notice. Hope Microelectronics assumes no responsibility or liability for any use of the information contained herein. Nothing in this document shall operate as an express or implied license or indemnity under the intellectual property rights of Hope Microelectronics or third parties. The products described in this document are not intended for use in implantation or other direct life support applications where malfunction may result in the direct physical harm or injury to persons. NO WARRANTIES OF ANY KIND, INCLUDING, BUT NOT LIMITED TO, THE IMPLIED WARRANTIES OF MECHANICALITY OR FITNESS FOR A PARTICULAR PURPOSE, ARE OFFERED IN THIS DOCUMENT.

©2006, HOPE MICROELECTRONICS CO.,LTD. All rights reserved.

## RF12 programming guide

### 1. Brief description

RF12B is a low cost FSK transceiver IC with integrated all RF functions in a single chip. It only need a MCU, a crystal, a decouple capacitor and antenna to build a hi reliable FSK transceiver system. The operation frequency can cover 400 to 1000MHz.

RF12B supports a command interface to setup frequency, deviation, output power and also data rate. No need any hardware adjustment when using in frequency-hopping applications

RF12B can be used in applications such as remote control toys, wireless alarm, wireless sensor, wireless keyboard/mouse, home-automation and wireless data collection.

### 2. Commands

#### 1. Timing diagram

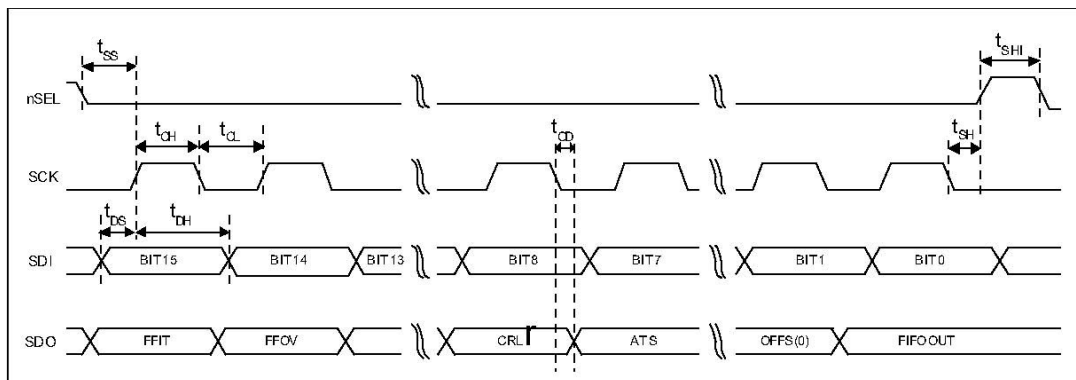

#### 2. Configuration Setting Command

bit	15	14	13	12	11	10	9	8	7	6	5	4	3	2	1	0	POR
	1	0	0	0	0	0	0	0	e1	ef	b1	b0	x3	x2	x1	x0	8008h

e 1: Enable TX register

e f: Enable RX FIFO buffer

b1..b0: select band

b1	b0	band[MHz]
0	0	Reserved
0	1	433
1	0	868
1	1	915

x3..x0: select crystal load capacitor

x3	x2	x1	x0	load capacitor [pF]
0	0	0	0	8.5
0	0	0	1	9.0
0	0	1	0	9.5
0	0	1	1	10.0
.....				.....
1	1	1	0	15.5
1	1	1	1	16.0

### 3. Power Management Command

bit	15	14	13	12	11	10	9	8	7	6	5	4	3	2	1	0	POR
	1	0	0	0	0	0	1	0	er	ebb	et	es	ex	eb	ew	dc	8208h

er: Enable receiver

ebb: Enable base band block

et: Enable transmitter

es: Enable synthesizer

ex: Enable crystal oscillator

eb: Enable low battery detector

ew: Enable wake-up timer

dc: Disable clock output of CLK pin

### 4. Frequency Setting Command

bit	15	14	13	12	11	10	9	8	7	6	5	4	3	2	1	0	POR
	1	0	1	0	f11	f10	f9	f8	f7	f6	f5	f4	f3	f2	f1	f0	A680h

f11..f0: Set operation frequency:

433band:  $F_c = 430 + F * 0.0025$  MHz

868band:  $F_c = 860 + F * 0.0050$  MHz

915band:  $F_c = 900 + F * 0.0075$  MHz

$F_c$  is carrier frequency and  $F$  is the frequency parameter.  $36 \leq F \leq 3903$

## 5. Data Rate Command

bit	15	14	13	12	11	10	9	8	7	6	5	4	3	2	1	0	POR
	1	1	0	0	0	1	1	0	cs	r6	r5	r4	r3	r2	r1	r0	C623h

r6..r0: Set data rate:

$$BR=10000000/29/ (R+1) / (1+cs*7)$$

## 6. Receiver Control Command

bit	15	14	13	12	11	10	9	8	7	6	5	4	3	2	1	0	POR
	1	0	0	1	0	P16	d1	d0	i2	i1	i0	g1	g0	r2	r1	r0	9080h

P16: select function of pin16

P16	
0	Interrupt input
1	VDI output

i2..i0:select baseband bandwidth

i2	i1	i0	Baseband Bandwidth [kHz]
0	0	0	reserved
0	0	1	400
0	1	0	340
0	1	1	270
1	0	0	200
1	0	1	134
1	1	0	67
1	1	1	reserved

d1..d0: select VDI response time

d1	d0	Response
0	0	Fast
0	1	Medium
1	0	Slow
1	1	Always on

g1..g0: select LNA gain

g1	g0	LNA gain (dBm)
0	0	0
0	1	-6
1	0	-14
1	1	-20

r2..r0: select DRSSI threshold

r2	r1	r0	RSSIseth [dBm]
0	0	0	-103
0	0	1	-97
0	1	0	-91
0	1	1	-85
1	0	0	-79
1	0	1	-73
1	1	0	Reserved
1	0	1	Reserved

The actual DRSSI threshold is related to LNA setup:

$$RSSI_{th} = RSSI_{seth} + G_{LNA}$$

## 7. Data Filter Command

bit	15	14	13	12	11	10	9	8	7	6	5	4	3	2	1	0	POR
	1	1	0	0	0	0	1	0	al	ml	1	s	1	f2	f1	f0	C22Ch

al: Enable clock recovery auto-lock

ml: Enable clock recovery fast mode

s: select data filter type

s	Filter type
0	Digital filter
1	Analog RC filter

f1..f0: Set DQD threshold

## 8. FIFO and Reset Mode Command

bit	15	14	13	12	11	10	9	8	7	6	5	4	3	2	1	0	POR
	1	1	0	0	1	0	1	0	f3	f2	f1	f0	sp	al	ff	dr	CA80h

f3..f0: Set FIFO interrupt level

sp: Select the length of the synchron pattern:

sp	Byte1	Byte0 (POR)	Synchron Pattern (Byte1+Byte0)
0	2Dh	D4h	2DD4h
1	Not used	D4h	D4h

al: select FIFO fill start condition

al	condition
0	Sync-word
1	Always

ff: Enable FIFO fill

dr: Disable hi sensitivity reset mode

### 9. Synchron pattern Command

bit	15	14	13	12	11	10	9	8	7	6	5	4	3	2	1	0	POR
	1	1	0	0	1	1	1	0	b7	b6	b5	b4	b3	b2	b1	b0	CED4h

This command is used to reprogram the synchronic pattern;

### 10. Receiver FIFO Read Command

bit	15	14	13	12	11	10	9	8	7	6	5	4	3	2	1	0	POR
	1	0	1	1	0	0	0	0	0	0	0	0	0	0	0	0	B00h

This command is used to read FIFO data when FFIT interrupt generated. FIFO data output starts at 8<sup>th</sup> SCK period.

### 11. AFC Command

bit	15	14	13	12	11	10	9	8	7	6	5	4	3	2	1	0	POR
	1	1	0	0	0	1	0	0	a1	a0	r1	r0	st	fi	oe	en	C4F7h

a1..a0: select AFC auto-mode:

a1	a0	
0	0	Controlled by MCU
0	1	Run once at power on
1	0	Keep offset when VDI hi
1	1	Keeps independently from VDI

r1..r0: select range limit

r1	r0	range (fres)
0	0	No restriction
0	1	+15/-16
1	0	+7/-8
1	1	+3-4

fres

315, 433band: 2.5kHz

868band: 5kHz

915band: 7.5kHz

st: st goes hi will store offset into output register

fi: Enable AFC hi accuracy mode

oe: Enable AFC output register

en: Enable AFC function

## 12. TX Configuration Control Command

bit	15	14	13	12	11	10	9	8	7	6	5	4	3	2	1	0	POR
	1	0	0	1	1	0	0	mp	m3	m2	m1	m0	0	p2	p1	p0	9800h

m: select modulation polarity

m2..m0: select frequency deviation:

m3	m2	m1	m0	frequency deviation [kHz]
0	0	0	0	15
0	0	0	1	30
0	0	1	0	45
0	0	1	1	60
0	1	0	0	75
0	1	0	1	90
0	1	1	0	105
0	1	1	1	120
1	0	0	0	135
1	0	0	1	150
1	0	1	0	165
1	0	1	1	180
1	1	0	0	195
1	1	0	1	210
1	1	1	0	225
1	1	1	1	240

p2..p0: select output power

p2	p1	p0	Output power[dBm]
0	0	0	0
0	0	1	-3
0	1	0	-6
0	1	1	-9
1	0	0	-12
1	0	1	-15
1	1	0	-18
1	0	1	-21

### 13. PLL Setting Command

bit	15	14	13	12	11	10	9	8	7	6	5	4	3	2	1	0	POR
	1	1	0	0	1	1	0	0	0	ob1	ob0	lpx	ddy	ddit	1	bw0	CC67h

ob1-ob0: Microcontroller output clock buffer rise and fall time control.

ob1	ob0	Selected uC CLK frequency
0	0	5 or 10 MHz (recommended)
0	1	3.3 MHz
1	X	2.5 MHz or less

lpx: select low power mode of the crystal oscillator.

lpx	Crystal start-up time (typ)	Power consumption (typ)
0	1 ms	620 uA
1	2 ms	460 uA

ddy: phase detector delay enable.

ddi: disables the dithering in the PLL loop.

bw1-bw0: select PLL bandwidth

bw0	Max bit rate [kbps]	Phase noise at 1MHz offset [dBc/Hz]
0	86.2	-107
1	256	-102

### 14. Transmitter Register Write Command

bit	15	14	13	12	11	10	9	8	7	6	5	4	3	2	1	0	POR
	1	0	1	1	1	0	0	0	t7	t6	t5	t4	t3	t2	t1	t0	B8AAh

This command is use to write a data byte to RF12 and then RF12 transmit it

### 15. Wake-Up Timer Command

bit	15	14	13	12	11	10	9	8	7	6	5	4	3	2	1	0	POR
	1	1	1	r4	r3	r2	r1	r0	m7	m6	m5	m4	m3	m2	m1	m0	E196h

The wake-up period is determined by:

$$T_{\text{wake-up}} = M * 2^R \text{ [ms]}$$

For continual operation, bit 'ew' must be cleared and set

### 16. Low Duty-Cycle Command

bit	15	14	13	12	11	10	9	8	7	6	5	4	3	2	1	0	POR
	1	1	0	0	1	0	0	0	d6	d5	d4	d3	d2	d1	d0	en	C80Eh

d6..d0: Set duty cycle

$$D. C. = (D * 2 + 1) / M * 100\%$$

en: Enable low duty cycle mode

### 17. Low Battery Detector and Microcontroller Clock Divider Command

bit	15	14	13	12	11	10	9	8	7	6	5	4	3	2	1	0	POR
	1	1	0	0	0	0	0	0	d2	d1	d0	0	v3	v2	v1	v0	C000h

d2..d0: select frequency of CLK pin

d2	d1	d0	Clock frequency[MHz]
0	0	0	1
0	0	1	1.25
0	1	0	1.66
0	1	1	2
1	0	0	2.5
1	0	1	3.33
1	1	0	5
1	1	1	10

CLK signal is derive form crystal oscillator and it can be applied to MCU clock in to save a second crystal.

If not used, please set bit “dc” to disable CLK output

To integrate the load capacitor internal can not only save cost, but also adjust reference frequency by software

v3..v0: Set threshold voltage of Low battery detector:

$$V_{lb} = 2.2 + V * 0.1 \text{ [V]}$$

### 18. Status Read Command

bit	15	14	13	12	11	10	9	8	7	6	5	4	3	2	1	0	POR
	0	x	x	x	x	x	x	x	x	x	x	x	x	x	x	x	-

This command starts with a 0 and be used to read internal status register

### 3. Demo flow diagram

Transmitter:

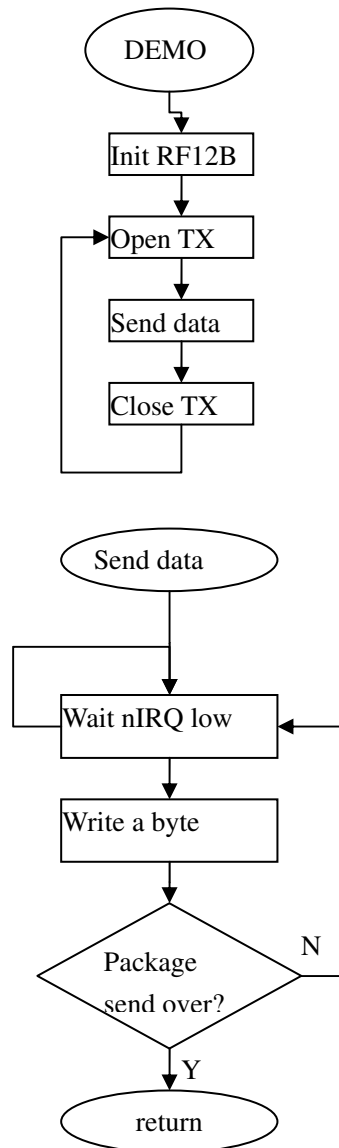

Note: Initialize RF12B and open transmitter, RF12B will transmit a byte and pull nIRQ low when transmit over, then MCU can write next byte to transmit

Receiver:

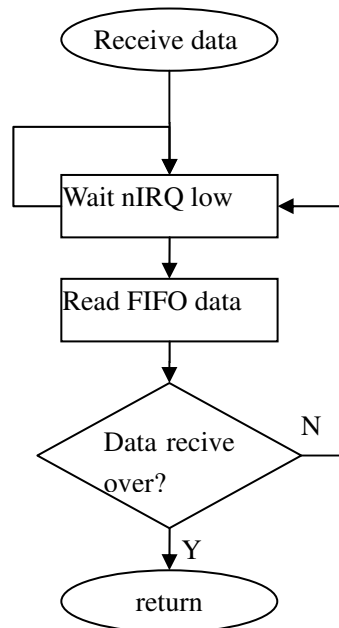
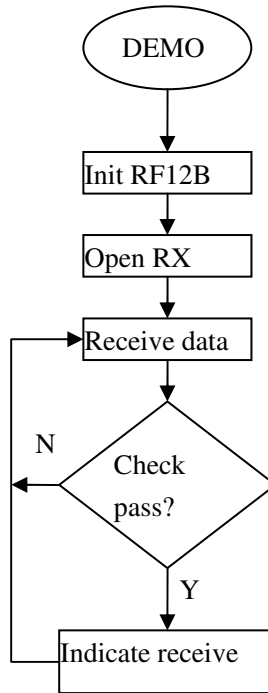

**Note:** After RF12B initialization, Open FIFO receive mode and wait nIRQ low, only then MCU

can read received and stored in FIFO data. For next package receive, please reset FIFO.

## 4. Example 1 (for AVR microcontroller)

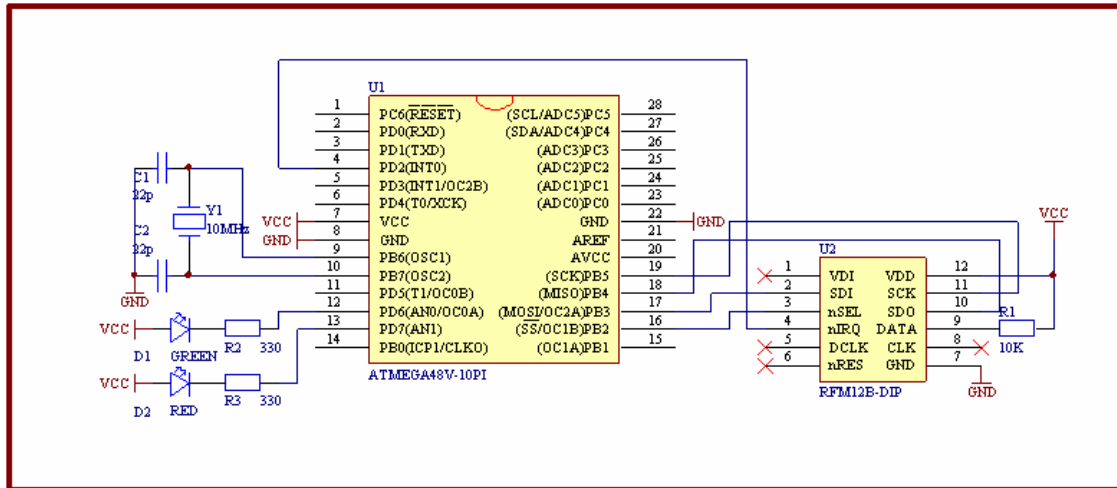

RF12 transmitter demo:

/\*

```

; copyright (c) 2006
;Title           RF12 TX simple example based on AVR C
;Company:        Hope microelectronic Co.,Ltd.
;Author:         Tank
;Current version: v1.0
;Date:           2006-11-13
;processor       ATMEGA48
;Clock:          10MHz Crystal
;Contact:        +86-0755-86106557
;E-MAIL:         hopefsk@hoperf.com
    
```

Connections

ATMEGA48 SIDE	RF12 SIDE
SCK----->	SCK
MISO----->	SDO
MOSI----->	SDI
SS----->	nSEL
INT0<-----	nIRQ
PD6: LED GREEN	
PD7: LED RED	

\*/

```
#include <mega48.h>

#define DDR_IN          0
#define DDR_OUT        1

#define PORT_SEL        PORTB
#define PIN_SEL         PINB
#define DDR_SEL         DDRB

#define PORT_SDI        PORTB
#define PIN_SDI         PINB
#define DDR_SDI         DDRB

#define PORT_SCK        PORTB
#define PIN_SCK         PINB
#define DDR_SCK         DDRB

#define PORT_SDO        PORTB
#define PIN_SDO         PINB
#define DDR_SDO         DDRB

#define PORT_DATA       PORTD
#define PIN_DATA        PIND
#define DDR_DATA        DDRD

#define PB7              7/--\
#define PB6              6// |
#define RFXX_SCK         5// |
#define RFXX_SDO         4// |RF_PORT
#define RFXX_SDI         3// |
#define RFXX_SEL         2// |
#define NC               1// |
#define PB0              0/--/

#define SEL_OUTPUT()    DDR_SEL |= (1<<RFXX_SEL)
#define HI_SEL()        PORT_SEL |= (1<<RFXX_SEL)
#define LOW_SEL()       PORT_SEL&=~(1<<RFXX_SEL)

#define SDI_OUTPUT()    DDR_SDI |= (1<<RFXX_SDI)
```

```
#define HI_SDI()          PORT_SDI |= (1<<RFXX_SDI)
#define LOW_SDI()         PORT_SDI&=~(1<<RFXX_SDI)

#define SDO_INPUT()      DDR_SDO&= ~(1<<RFXX_SDO)
#define SDO_HI()         PIN_SDO&(1<<RFXX_SDO)

#define SCK_OUTPUT()     DDR_SCK |= (1<<RFXX_SCK)
#define HI_SCK()         PORT_SCK |= (1<<RFXX_SCK)
#define LOW_SCK()        PORT_SCK&=~(1<<RFXX_SCK)

#define RF12_DATA        4//PD4
#define DATA_OUT        DDR_DATA |=1<<RF12_DATA
#define HI_DATA          PORT_DATA |=1<<RF12_DATA

#define LEDG_OUTPUT()    DDRD |=~(1<<6)
#define LEDR_OUTPUT()    DDRD |=~(1<<7)

#define LEDG_ON()        PORTD&=~(1<<6)
#define LEDG_OFF()       PORTD |=~(1<<6)
#define LEDR_ON()        PORTD&=~(1<<7)
#define LEDR_OFF()       PORTD |=~(1<<7)

void RFXX_PORT_INIT(void) {
    HI_SEL();
    HI_SDI();
    LOW_SCK();
    SEL_OUTPUT();
    SDI_OUTPUT();
    SDO_INPUT();
    SCK_OUTPUT();
}

unsigned int RFXX_WRT_CMD(unsigned int aCmd) {
    unsigned char i;
    unsigned int temp;
    LOW_SCK();
    LOW_SEL();
    for(i=0;i<16;i++) {
        temp<<=1;
        if(SDO_HI()) {
            temp|=0x0001;
        }
        LOW_SCK();
        if(aCmd&0x8000) {
```

```
    HI_SDI();
  }else{
    LOW_SDI();
  }
  HI_SCK();
  aCmd<<=1;
};
LOW_SCK();
HI_SEL();
return(temp);
}
void RF12_INIT(void) {
  RFXX_WRT_CMD(0x80D7); //EL, EF, 433band, 12.0pF
  RFXX_WRT_CMD(0x8239); //!er, !ebb, ET, ES, EX, !eb, !ew, DC
  RFXX_WRT_CMD(0xA640); //434MHz
  RFXX_WRT_CMD(0xC647); //4.8kbps
  RFXX_WRT_CMD(0x94A0); //VDI, FAST, 134kHz, 0dBm, -103dBm
  RFXX_WRT_CMD(0xC2AC); //AL, !m1, DIG, DQD4
  RFXX_WRT_CMD(0xCA81); //FIFO8, SYNC, !ff, DR
  RFXX_WRT_CMD(0xCED4); //SYNC=2DD4;
  RFXX_WRT_CMD(0xC483); //@PWR, NO RSTRIC, !st, !fi, OE, EN
  RFXX_WRT_CMD(0x9850); //!mp, 90kHz, MAX OUT
  RFXX_WRT_CMD(0xCC77); //OB1, OB0, LPX, !ddy, DDIT, BW0
  RFXX_WRT_CMD(0xE000); //NOT USE
  RFXX_WRT_CMD(0xC800); //NOT USE
  RFXX_WRT_CMD(0xC040); //1.66MHz, 2.2V
}
void RF12_SEND(unsigned char aByte) {
  while(PIND&(1<<2)); //wait for previously TX over
  RFXX_WRT_CMD(0xB800+aByte);
}

void Delay_ms(unsigned char amS) {
  unsigned char i;
  unsigned int j;
  for(i=0; i<amS; i++) for(j=0; j<914; j++);
}
void main(void)
{
  unsigned int i, j;
  unsigned char ChkSum;

  #asm("cli");
  DDRB=0x00; //PB INPUT;
```

```
DDRD=0x00;//PD INPUT;

//POWER ON indication: both LEDR and LEDG blink 3 times
LEDG_OFF();
LEDR_OFF();
LEDG_OUTPUT();
LEDR_OUTPUT();
for(i=0;i<3;i++){
    Delay_ms(200);
    LEDG_ON();
    LEDR_ON();
    Delay_ms(200);
    LEDG_OFF();
    LEDR_OFF();
}

    LEDG_OFF();
    LEDR_OFF();

RFXX_PORT_INIT();

RF12_INIT();

DDRD|=(1<<RF12_DATA);
PORTD|=(1<<RF12_DATA);// SET nFFS pin HI when using TX register
DDRD&=~(1<<2);          //PD2(INT0)

while(1){
    LEDR_ON();
    RFXX_WRT_CMD(0x0000);//read status register
    RFXX_WRT_CMD(0x8239);//!er, !ebb, ET, ES, EX, !eb, !ew, DC

    ChkSum=0;
    RF12_SEND(0xAA);//PREAMBLE
    RF12_SEND(0xAA);//PREAMBLE
    RF12_SEND(0xAA);//PREAMBLE
    RF12_SEND(0x2D);//SYNC HI BYTE
    RF12_SEND(0xD4);//SYNC LOW BYTE
    RF12_SEND(0x30);//DATA BYTE 0
    ChkSum+=0x30;
    RF12_SEND(0x31);//DATA BYTE 1
    ChkSum+=0x31;
    RF12_SEND(0x32);
```

```
    ChkSum+=0x32;
    RF12_SEND(0x33);
    ChkSum+=0x33;
    RF12_SEND(0x34);
    ChkSum+=0x34;
    RF12_SEND(0x35);
    ChkSum+=0x35;
    RF12_SEND(0x36);
    ChkSum+=0x36;
    RF12_SEND(0x37);
    ChkSum+=0x37;
    RF12_SEND(0x38);
    ChkSum+=0x38;
    RF12_SEND(0x39);
    ChkSum+=0x39;
    RF12_SEND(0x3A);
    ChkSum+=0x3A;
    RF12_SEND(0x3B);
    ChkSum+=0x3B;
    RF12_SEND(0x3C);
    ChkSum+=0x3C;
    RF12_SEND(0x3D);
    ChkSum+=0x3D;
    RF12_SEND(0x3E);
    ChkSum+=0x3E;
    RF12_SEND(0x3F);    //DATA BYTE 15
    ChkSum+=0x3F;
    RF12_SEND(ChkSum); //send chek sum
    RF12_SEND(0xAA); //DUMMY BYTE
    RF12_SEND(0xAA); //DUMMY BYTE
    RF12_SEND(0xAA); //DUMMY BYTE

    RFXWRT_CMD(0x8201);
    LEDR_OFF();
    LEDG_OFF();
    for(i=0;i<10000;i++) for(j=0;j<123;j++) //sleep 1 second appr.

};
}
```

RF12 receiver demo

/\*

```
; copyright (c) 2006
;Title           RF12 RX simple example based on AVR C
;Company:        Hope microelectronic Co.,Ltd.
;Author:         Tank
;Current version: v1.0
;Date:           2006-11-17
;processor        ATMEGA48
;Clock:          10MHz Crystal
;Contact:        +86-0755-86106557
;E-MAIL:         hopefsk@hoperf.com
```

### Connections

```
ATMEGA48 SIDE      RF12 SIDE
SCK----->SCK
MISO<-----SDO
MOSI----->SDI
SS----->nSEL
PD4----->FSK/DATA
INT0<-----nIRQ
```

```
PD6: LED GREEN
PD7: LED RED
```

\*/

```
#include <mega48.h>
```

```
#define DDR_IN      0
#define DDR_OUT     1

#define PORT_SEL    PORTB
#define PIN_SEL     PINB
#define DDR_SEL     DDRB

#define PORT_SDI    PORTB
#define PIN_SDI     PINB
#define DDR_SDI     DDRB

#define PORT_SCK    PORTB
#define PIN_SCK     PINB
#define DDR_SCK     DDRB
```

```
#define PORT_SDO          PORTB
#define PIN_SDO           PINB
#define DDR_SDO          DDRB

#define PORT_IRQ         PORTD
#define PIN_IRQ          PIND
#define DDR_IRQ          DDRD

#define PORT_DATA        PORTD
#define PIN_DATA         PIND
#define DDR_DATA         DDRD

#define PB7              7//--\
#define PB6              6// |
#define RFXX_SCK         5// |
#define RFXX_SDO         4// |RF_PORT
#define RFXX_SDI         3// |
#define RFXX_SEL         2// |
#define NC               1// |
#define PB0              0//--/

#define SEL_OUTPUT()     DDR_SEL |= (1<<RFXX_SEL)
#define HI_SEL()         PORT_SEL |= (1<<RFXX_SEL)
#define LOW_SEL()        PORT_SEL&=~(1<<RFXX_SEL)

#define SDI_OUTPUT()     DDR_SDI |= (1<<RFXX_SDI)
#define HI_SDI()         PORT_SDI |= (1<<RFXX_SDI)
#define LOW_SDI()        PORT_SDI&=~(1<<RFXX_SDI)

#define SDO_INPUT()      DDR_SDO&= ~(1<<RFXX_SDO)
#define LOW_SDO()        PORT_SDO&= (1<<RFXX_SDO)
#define SDO_HI()         PIN_SDO&(1<<RFXX_SDO)

#define SCK_OUTPUT()     DDR_SCK |= (1<<RFXX_SCK)
#define HI_SCK()         PORT_SCK |= (1<<RFXX_SCK)
#define LOW_SCK()        PORT_SCK&=~(1<<RFXX_SCK)

#define RF12_IRQ         2
#define IRQ_IN()         DDR_IRQ &=~(1<<RF12_IRQ)
#define WAIT_IRQ_LOW()  while(PIND&(1<<RF12_IRQ))

#define RF12_DATA         4//PD4
#define DATA_OUT()       DDR_DATA |=1<<RF12_DATA
```

```
#define HI_DATA()      PORT_DATA|=1<<RF12_DATA

#define LEDG_OUTPUT()  DDRD|=~(1<<6)
#define LEDR_OUTPUT()  DDRD|=~(1<<7)

#define LEDG_ON()      PORTD&=~(1<<6)
#define LEDG_OFF()     PORTD|= (1<<6)
#define LEDR_ON()      PORTD&=~(1<<7)
#define LEDR_OFF()     PORTD|= (1<<7)
```

```
void RFX_PORT_INIT(void) {
    HI_SEL();
    HI_SDI();
    LOW_SCK();
    //SET nFFS pin HI when using FIFO
    HI_DATA();
    SEL_OUTPUT();
    SDI_OUTPUT();
    SDO_INPUT();
    SCK_OUTPUT();
    IRQ_IN();
    DATA_OUT();
}

unsigned int RFX_WRT_CMD(unsigned int aCmd) {
    unsigned char i;
    unsigned int temp;
    temp=0;
    LOW_SCK();
    LOW_SEL();
    for(i=0;i<16;i++) {
        if(aCmd&0x8000) {
            HI_SDI();
        }else{
            LOW_SDI();
        }
        HI_SCK();
        temp<<=1;
        if(SDO_HI()) {
            temp|=0x0001;
        }
        LOW_SCK();

        aCmd<<=1;
    }
}
```

```
};
HI_SEL();
return(temp);
}

void RF12_INIT(void) {
    RFXX_WRT_CMD(0x80D7); //EL, EF, 433band, 12. 0pF
    RFXX_WRT_CMD(0x8239); //!er, !ebb, ET, ES, EX, !eb, !ew, DC
    RFXX_WRT_CMD(0xA640); //434MHz
    RFXX_WRT_CMD(0xC647); //4. 8kbps
    RFXX_WRT_CMD(0x94A0); //VDI, FAST, 134kHz, 0dBm, -103dBm
    RFXX_WRT_CMD(0xC2AC); //AL, !m1, DIG, DQD4
    RFXX_WRT_CMD(0xCA81); //FIF08, SYNC, !ff, DR
    RFXX_WRT_CMD(0xCED4); //SYNC=2DD4;
    RFXX_WRT_CMD(0xC483); //@PWR, NO RSTRIC, !st, !fi, OE, EN
    RFXX_WRT_CMD(0x9850); //!mp, 90kHz, MAX OUT
    RFXX_WRT_CMD(0xCC77); //OB1, OBO, LPX, !ddy, DDIT, BW0
    RFXX_WRT_CMD(0xE000); //NOT USE
    RFXX_WRT_CMD(0xC800); //NOT USE
    RFXX_WRT_CMD(0xC040); //1. 66MHz, 2. 2V
}

unsigned char RF12_RECV(void) {
    unsigned int FIFO_data;
    WAIT_IRQ_LOW();
    RFXX_WRT_CMD(0x0000);
    FIFO_data=RFXX_WRT_CMD(0xB000);
    return(FIFO_data&0x00FF);
}

void Delay_ms(unsigned char amS) {
    unsigned char i;
    unsigned int j;
    for(i=0; i<amS; i++) for(j=0; j<914; j++);
}

void main(void)
{
    unsigned char i;
    unsigned char ChkSum;

    //POWER ON indication: both LEDR and LEDG blink 3 times

    LEDG_OFF();
    LEDR_OFF();
    LEDG_OUTPUT();
    LEDR_OUTPUT();
}
```

```
for(i=0;i<3;i++){
    Delay_ms(200);
    LEDG_ON();
    LEDR_ON();
    Delay_ms(200);
    LEDG_OFF();
    LEDR_OFF();
}

    LEDG_OFF();
    LEDR_OFF();

//Initialize command port
RFXX_PORT_INIT();

//Initialize RF12 chip
RF12_INIT();

//Init FIFO
RFXX_WRT_CMD(0xCA81);

while(1){
    //Enable FIFO
    RFXX_WRT_CMD(0xCA83);
    ChkSum=0;

    //Receive payload data
    for(i=0;i<16;i++){
        ChkSum+=RF12_RECV();
    }

    //Receive Check sum
    i=RF12_RECV();

    //Disable FIFO
    RFXX_WRT_CMD(0xCA81);

    //Package check
    if(ChkSum==i){
        LEDG_ON();
        Delay_ms(200);
        LEDG_OFF();
    }
}
```

}

## 5. Example 2 (for PIC microcontroller)

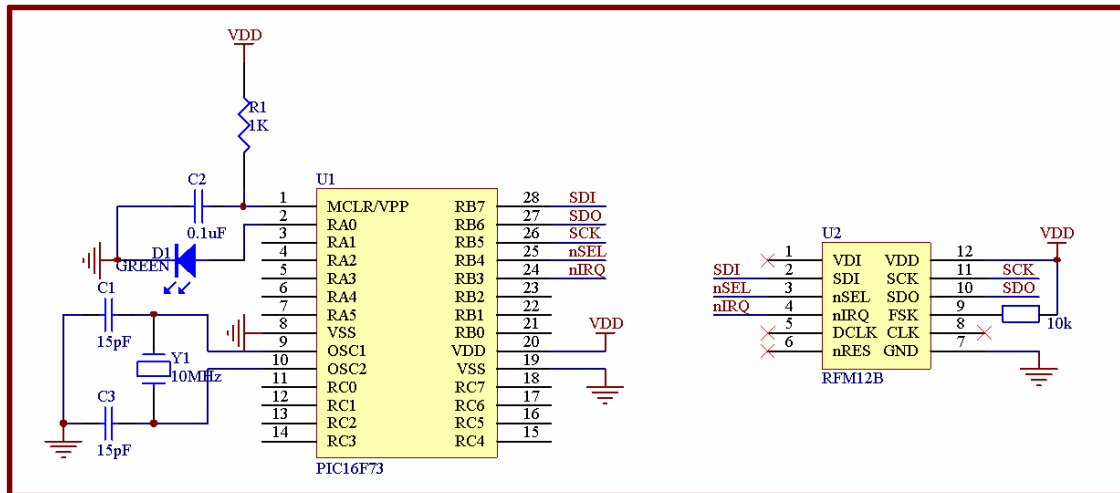

RF12 transmitter demo:

/\*\*\*\*\*\*

copyright (c) 2006

Title: RFM12A transmitter simple example based on PIC C

Current version: v1.0

Function: Package send Demo

Processor PIC16F73 DIP-28

Clock: 10MHz Crystal

Operate frequency: 434MHz

Data rate: 4.8kbps

Package size: 23byte

Author: Robben

Company: Hope microelectronic Co.,Ltd.

Contact: +86-0755-86106557

E-MAIL: hopefsk@hoperf.com

Date: 2006-11-21

\*\*\*\*\*/

#include "pic.h"

typedef unsigned char uchar;

typedef unsigned int uint;

```
#define SDI          RB7
#define SDO          RB6
#define SCK          RB5
#define nSEL        RB4

#define SDI_OUT()   TRISB7=0
#define SDO_IN()   TRISB6=1
#define SCK_OUT()   TRISB5=0
#define nSEL_OUT()  TRISB4=0

void Init_RF12(void);
void Write0( void );
void Write1( void );
void WriteCMD( uint CMD );
void DelayUs( uint us );
void DelayMs( uint ms );
void WriteFSKbyte( uchar DATA );

__CONFIG(0x3FF2);

void Init_RF12(void)
{
    nSEL_OUT();
    SDI_OUT();
    SDO_IN();
    SCK_OUT();
    nSEL=1;
    SDI=1;
    SCK=0;
    WriteCMD(0x80D8); //enable register, 433MHz, 12. 5pF
    WriteCMD(0x8208); //Turn on crystal, !PA
    WriteCMD(0xA640); //
    WriteCMD(0xC647); //
    WriteCMD(0x94C0); //VDI, FAST, 134kHz, 0dBm, -103dBm
    WriteCMD(0xC2AC);
    WriteCMD(0xCA80);
    WriteCMD(0xCED4);
    WriteCMD(0xCA83); //FIFO8, SYNC,
    WriteCMD(0xC49B);
    WriteCMD(0x9850); //!mp, 90kHz, MAX OUT
    WriteCMD(0xCC77);
    WriteCMD(0xE000); //NOT USE
    WriteCMD(0xC80E); //NOT USE
    WriteCMD(0xC000); //1. 0MHz, 2. 2V
```

```
}  
  
void main()  
{  
    uint ChkSum=0;  
    Init_RF12();  
    while(1)  
    {  
        WriteCMD(0x8228);    //OPEN PA  
        DelayUs( 4 );  
        WriteCMD(0x8238);  
        NOP();  
        NOP();  
        WriteFSKbyte( 0xAA );  
        WriteFSKbyte( 0xAA );  
        WriteFSKbyte( 0xAA );  
        WriteFSKbyte( 0x2D );  
        WriteFSKbyte( 0xD4 );  
  
        WriteFSKbyte( 0x30 );//DATA0  
        ChkSum+=0x30;  
        WriteFSKbyte( 0x31 );//DATA1  
        ChkSum+=0x31;  
        WriteFSKbyte( 0x32 );  
        ChkSum+=0x32;  
        WriteFSKbyte( 0x33 );  
        ChkSum+=0x33;  
        WriteFSKbyte( 0x34 );  
        ChkSum+=0x34;  
        WriteFSKbyte( 0x35 );  
        ChkSum+=0x35;  
        WriteFSKbyte( 0x36 );  
        ChkSum+=0x36;  
        WriteFSKbyte( 0x37 );  
        ChkSum+=0x37;  
        WriteFSKbyte( 0x38 );  
        ChkSum+=0x38;  
        WriteFSKbyte( 0x39 );  
        ChkSum+=0x39;  
        WriteFSKbyte( 0x3A );  
        ChkSum+=0x3A;  
        WriteFSKbyte( 0x3B );  
        ChkSum+=0x3B;  
        WriteFSKbyte( 0x3C );
```

```
    ChkSum+=0x3C;
    WriteFSKbyte(0x3D);
    ChkSum+=0x3D;
    WriteFSKbyte( 0x3E );
    ChkSum+=0x3E;
    WriteFSKbyte( 0x3F );//DATA15
    ChkSum+=0x3F;
    ChkSum&=0x0FF;
    WriteFSKbyte( ChkSum );
    WriteFSKbyte( 0xAA );
    WriteCMD( 0x8208 );      //CLOSE PA
    DelayMs(1000);

}
}
```

```
void Write0( void )
{
    SDI=0;
    SCK=0;
    NOP();
    NOP();
    NOP();
    NOP();
    NOP();
    NOP();
    NOP();
    NOP();
    NOP();
    NOP();
    NOP();
    NOP();
    NOP();
    NOP();
    NOP();
    NOP();
    NOP();
    NOP();
    SCK=1;
    NOP();
}
```

```
void Write1( void )
{
    SDI=1;
    SCK=0;
```

```
NOP();
NOP();
NOP();
NOP();
NOP();
NOP();
NOP();
NOP();
NOP();
NOP();
NOP();
NOP();
NOP();
NOP();
NOP();
NOP();
NOP();
NOP();
SCK=1;
NOP();
}

void WriteCMD( uint CMD )
{
    uchar n=16;
    SCK=0;
    nSEL=0;
    while(n--)
    {
        if(CMD&0x8000)
            Write1();
        else
            Write0();
        CMD=CMD<<1;
    }
    SCK=0;
    nSEL=1;
}

void WriteFSKbyte( uchar DATA )
{
    uchar RGIT=0;
    uint temp=0xB800;
    temp|=DATA;
Loop: SCK=0;
```

```
nSEL=0;
SDI=0;
SCK=1;
if (SD0)                //Polling SDO
{
    RGIT=1;
}
else
{
    RGIT=0;
}
SCK=0;
SDI=1;
nSEL=1;
if (RGIT==0)
{
    goto Loop;
}
else
{
    RGIT=0;
    WriteCMD(temp);
}
}
```

```
void DelayUs( uint us )
{
    uint i;
    while( us-- )
    {
        i=2;
        while( i-- )
        {
            NOP();
        }
    }
}
```

```
void DelayMs(uint ms)
{
    uchar i;
    while(ms-- )
    {
```

```
i=35;
while(i-->0)
{
    DelayUs(1);
}
}
```

RF12 receiver demo:

```
/*****
```

```
    copyright (c) 2006
```

```
Title:          RFM12A transmitter simple example based on PIC C
```

```
Current version: v1.0
```

```
Function:       Package send Demo
```

```
Processor       PIC16F73 DIP-28
```

```
Clock:          10MHz Crystal
```

```
Operate frequency: 434MHz
```

```
Data rate:      4.8kbps
```

```
Package size:   23byte
```

```
Author:         Robben
```

```
Company:        Hope microelectronic Co.,Ltd.
```

```
Contact:        +86-0755-86106557
```

```
E-MAIL:         hopefsk@hoperf.com
```

```
Date:           2006-11-17
```

```
*****/
```

```
#include "pic.h"
```

```
typedef unsigned char uchar;
```

```
typedef unsigned int uint;
```

```
#define SDI      RB7
```

```
#define SDO      RB6
```

```
#define SCK      RB5
```

```
#define nSEL     RB4
```

```
#define nIRQ     RB3
```

```
#define LED      RA0
```

```
#define LED_OUT() TRISA0=0
```

```
#define nIRQ_IN() TRISB3=1
```

```
#define SDI_OUT() TRISB7=0
```

```
#define SDO_IN() TRISB6=1
```

```
#define SCK_OUT() TRISB5=0
```

```
#define nSEL_OUT() TRISB4=0
```

```
void Init_RF12(void);
void Write0( void );
void Write1( void );
void WriteCMD( uint CMD );
uchar RF12_RDFIFO(void);
void Delayus( uint us );

__CONFIG(0x3FF2);
bank1 uchar RF_RXBUF[19];
void Init_RF12(void)
{

    LED_OUT();
    nSEL_OUT();
    SDI_OUT();
    SDO_IN();
    SCK_OUT();
    nIRQ_IN();
    nSEL=1;
    SDI=1;
    SCK=0;
    SDO=0;
    LED=0;
    WriteCMD(0x80D8); //enable register, 433MHz, 12. 5pF
    WriteCMD(0x82D8); //enable receive, !PA
    WriteCMD(0xA640); //
    WriteCMD(0xC647); //
    WriteCMD(0x94C0); //VDI, FAST, 134kHz, 0dBm, -103dBm
    WriteCMD(0xC2AC);
    WriteCMD(0xCA80);
    WriteCMD(0xCED4);
    WriteCMD(0xCA83); //FIFO8, SYNC,
    WriteCMD(0xC49B);
    WriteCMD(0x9850); //!mp, 90kHz, MAX OUT
    WriteCMD(0xCC77);
    WriteCMD(0xE000); //NOT USE
    WriteCMD(0xC800); //NOT USE
    WriteCMD(0xC000); //1. 0MHz, 2. 2V
}

void main()
{
    uchar i=0, j=0;
```

```
uint CheckSum;

Init_RF12();

while(1)
{
    while(!nIRQ)
    {
        RF_RXBUF[i++]=RF12_RDFIFO();
        if(i==17)
        {
            i=0;
            WriteCMD(0xCA80);
            WriteCMD(0xCA83);           //reset FIFO and read to receive next Byte
            CheckSum=0;
            for(j=0;j<16;j++)
                CheckSum+=RF_RXBUF[j]; //add 0x30-----0x3F
            CheckSum&=0x0FF;
            if(CheckSum==RF_RXBUF[16])
            {
                LED=1;
            }
            Delayus(1);
            LED=0;
        }
    }
}

void Write0( void )
{
    SDI=0;
    SCK=0;
    NOP();
    NOP();
    NOP();
    NOP();
    NOP();
    NOP();
    NOP();
    NOP();
    NOP();
    NOP();
    NOP();
    NOP();
    NOP();
    NOP();
}
```

```
NOP();
NOP();
NOP();
NOP();
NOP();
SCK=1;
NOP();
}

void Writel( void )
{
    SDI=1;
    SCK=0;
    NOP();
    NOP();
    NOP();
    NOP();
    NOP();
    NOP();
    NOP();
    NOP();
    NOP();
    NOP();
    NOP();
    NOP();
    NOP();
    NOP();
    NOP();
    NOP();
    SCK=1;
    NOP();
}

void WriteCMD( uint CMD )
{
    uchar n=16;
    SCK=0;
    nSEL=0;
    while(n-->0)
    {
        if(CMD&0x8000)
            Writel();
        else
            Write0();
    }
}
```

```
    CMD=CMD<<1;
}
SCK=0;
nSEL=1;
}

uchar RF12_RDFIFO(void)
{
    uchar i,Result;
    SCK=0;
    SDI=0;
    nSEL=0;
    for(i=0;i<16;i++)
    {
        //skip status bits
        SCK=1;
        NOP();
        NOP();
        SCK=0;
        NOP();
        NOP();
    }
    Result=0;
    for(i=0;i<8;i++)
    {
        //read fifo data byte
        Result=Result<<1;
        if(SDO)
        {
            Result|=1;
        }
        SCK=1;
        NOP();
        NOP();
        SCK=0;
        NOP();
        NOP();
    }
    nSEL=1;
    return(Result);
}

void Delayus( uint us )
{
    uint i;
```

```
while( us-- )
{
    i=1000;
    while( i-- )
    {
        NOP();
    }
}
```

**HOPE MICROELECTRONICS CO.,LTD**

Address: Rm B.8/F LiJingGe Emperor  
Regency 6012 ShenNan Rd, Shenzhen, China

Tel: 86-755-82973805

Fax: 86-755-82973550

Email: [sales@hoperf.com](mailto:sales@hoperf.com)

[trade@hoperf.com](mailto:trade@hoperf.com)

Website: <http://www.hoperf.com>

<http://www.hoperf.cn>

<http://hoperf.en.alibaba.com>

This document may contain preliminary information and is subject to change by Hope Microelectronics without notice. Hope Microelectronics assumes no responsibility or liability for any use of the information contained herein. Nothing in this document shall operate as an express or implied license or indemnity under the intellectual property rights of Hope Microelectronics or third parties. The products described in this document are not intended for use in implantation or other direct life support applications where malfunction may result in the direct physical harm or injury to persons. NO WARRANTIES OF ANY KIND, INCLUDING, BUT NOT LIMITED TO, THE IMPLIED WARRANTIES OF MERCHANTABILITY OR FITNESS FOR A PARTICULAR PURPOSE, ARE OFFERED IN THIS DOCUMENT.

©2006, HOPE MICROELECTRONICS CO.,LTD. All rights reserved.